

**DANIEL ARGYLE**

**UNTITLED 2006**

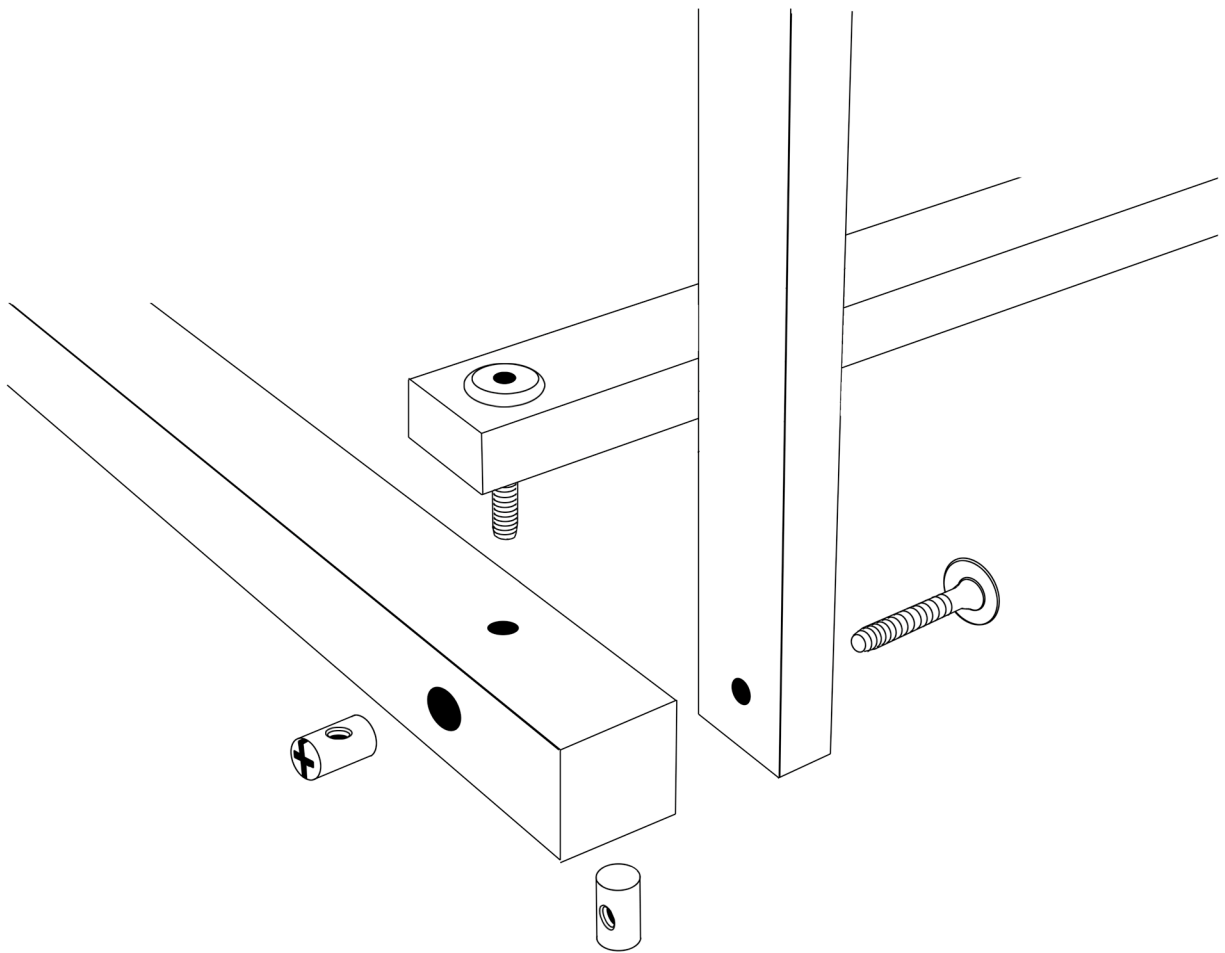

**ASSEMBLY INSTRUCTIONS FOR FLAT-PACKABLE ARTWORK**

**IMPORTANT:** Use only the hardware and fixings provided. If substitutions need to be made, consult the artist.

## STEP 1:

For each unit, identify two “A” posts and two “B” posts. Note that posts are unmarked so observe differences in configuration of holes. Observe also that first nail hole up is 307 mm from base – this dimension indicates the base of the post, and will help differentiate the two different types of post.

Locate four long struts and four short struts. Put aside the other four long and four short struts for assembly of the second unit.

Observe diagram on right, noting that “A” posts are diagonally opposite each other. Insert a nut into the larger of the top two holes at the top of an “A” post. Insert a cross-tipped screwdriver into the hole and rotate the nut so that post and nut holes align. Bolt a long strut onto the top of the post, using the screwdriver to maintain alignment of the holes.

Locate a “B” post at the other end of the strut, observing the orientation of the holes in the diagram. Bolt the strut to the post as described in previous paragraph.

Bolt another long strut to the base of the posts. Proceed to bolt the four short struts to the top and base of the posts.

Finally, bolt the remaining “A” and “B” posts to the struts, and repeat the assembly process for the second unit.

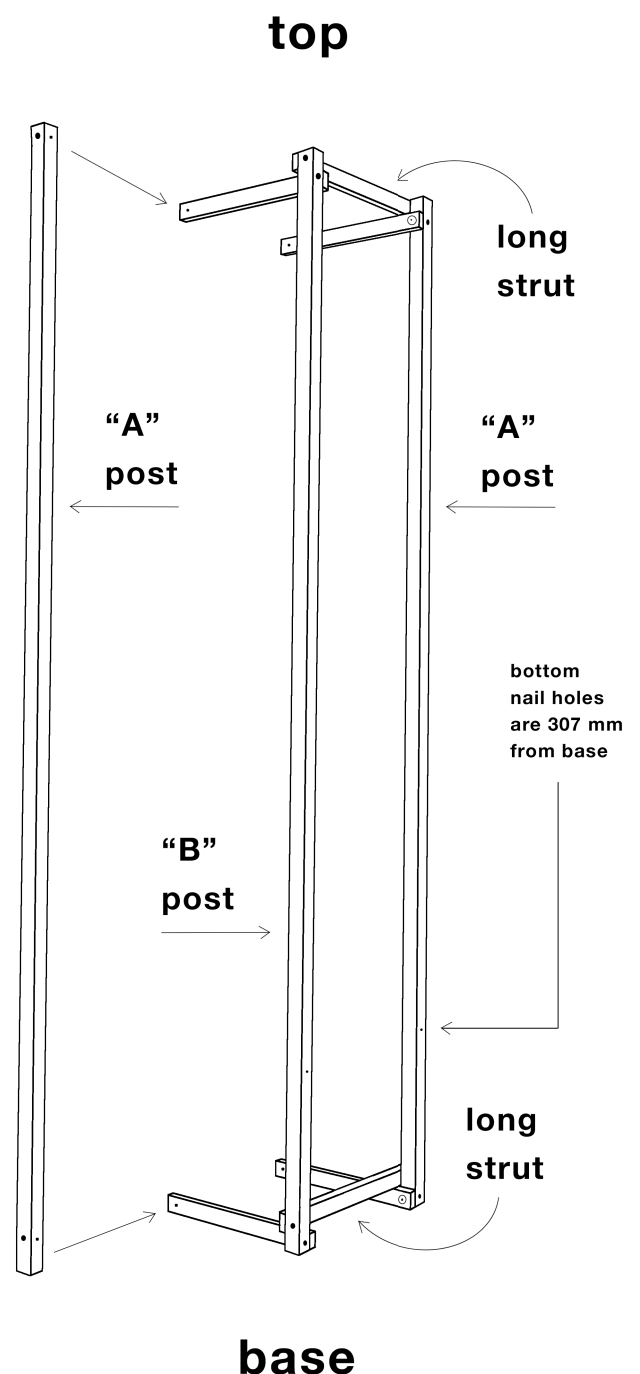

## STEP 2:

Affix brackets to wall, referring to the diagram below. Top edges of top brackets are fixed 1770 mm from floor. Top edges of bottom brackets are fixed 1062 mm from floor, or 708 mm down from top edges of top brackets. Ensure that horizontal distance between brackets is 1262 mm from outer edges.

Screws need to be torqued by hand, with the screwdriver provided, due to space restrictions inside brackets. It is advisable to drill pilot holes in the wall before attempting to screw brackets. Mark the top and outer edges of bracket on the wall, hold bracket against the wall in correct relation to these marks, and then carefully mark the wall through the holes in bracket.

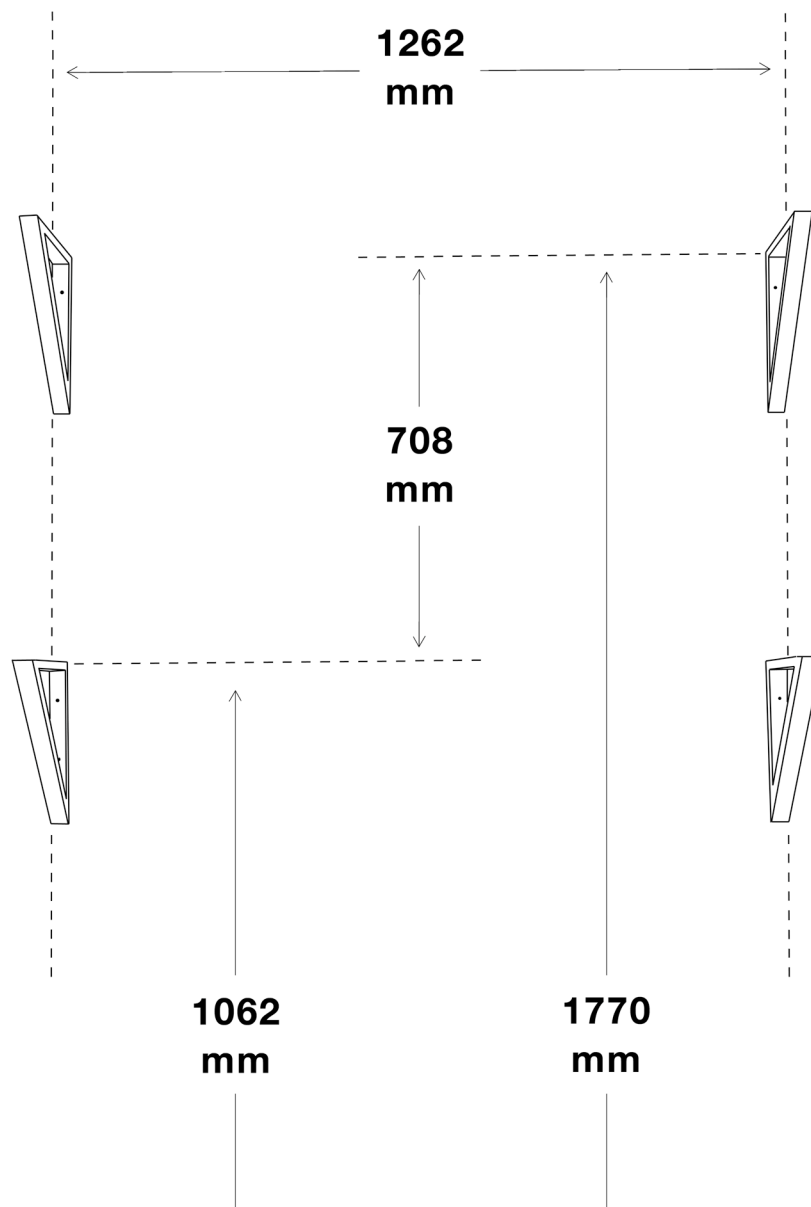

### STEP 3:

Place each unit onto the brackets as shown in diagram below, observing that units are centered on the brackets with equal overlap at each end.

Make sure the “top” of each unit is located on the right-hand side. If in doubt, refer to STEP 1.

The face of each unit should be flush with the front point of the brackets, leaving a small gap between the wall and the back of the unit.

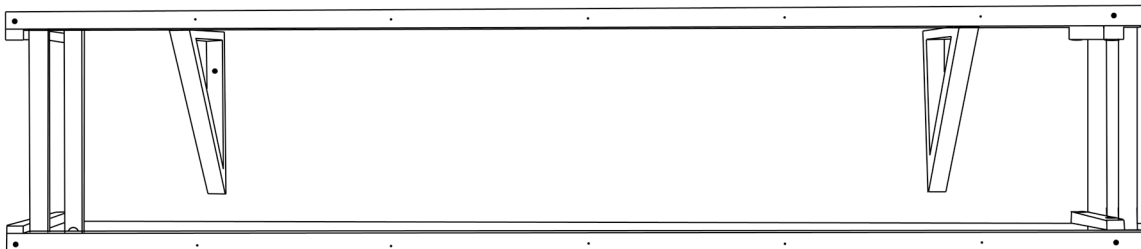
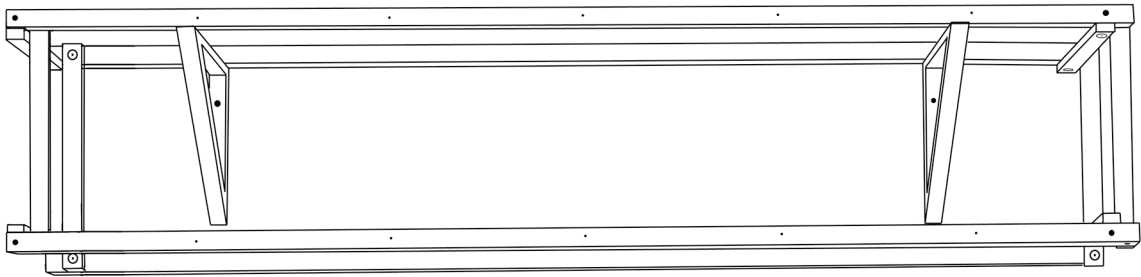

#### STEP 4:

Carefully attach the cardboard collars according to the diagram below (G = Green, B = Blue, P = Purple). Ensure that collars join at top-back of each unit.

At this stage nails can be used as stoppers, or guides, for the collars on the face of each unit. This option is left up to the discretion of the second-party (the curator, gallerist, or owner). Nails have been supplied for this purpose, and only these nails should be used. Do not use a hammer. Push nails into the holes. Only use nails in the holes next to a collar, ignoring the holes that don't abut the edge of collars – refer to diagram below. If nails are not to be used, collars should be spaced according to the holes provided – refer to diagram below.

